



Performance is everything.™

# User Guide

Vax Careline: AU: 1300 361 505  
NZ: 0800 800 900

## Duet Master

2 in 1 stick steam and handheld cleaner

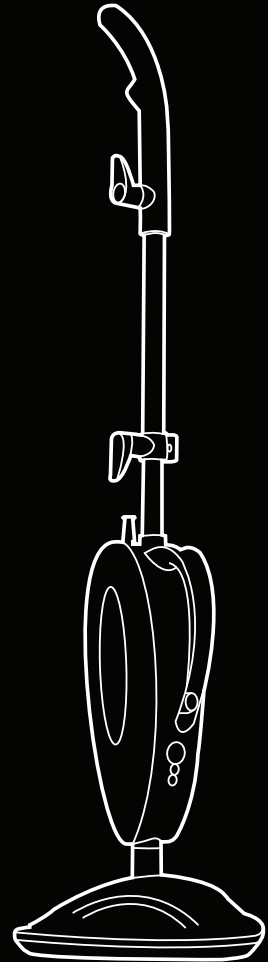

## Get Cleaning...

What's your Vax's model number?

V S T D U E T 1 6 0 0

What's your serial number? (Located on the base of the machine)

Serial number input field with 15 empty boxes

Note these down in case you need them in future. Please keep instructions for further use.

Vax Service line: AU: 1300 361 505  
NZ: 0800 800 900

# Machine Overview

- 1 Handle
- 2 Upper cord clip
- 3 Power cord
- 4 Lower cord clip
- 5 Clean water tank
- 6 LED indicator
  - a) Water heating/power on  
(blue LED)
  - b) Steam ready  
(blue LED) + (green LED)
- 7 Floor head
- 8 Steam release trigger

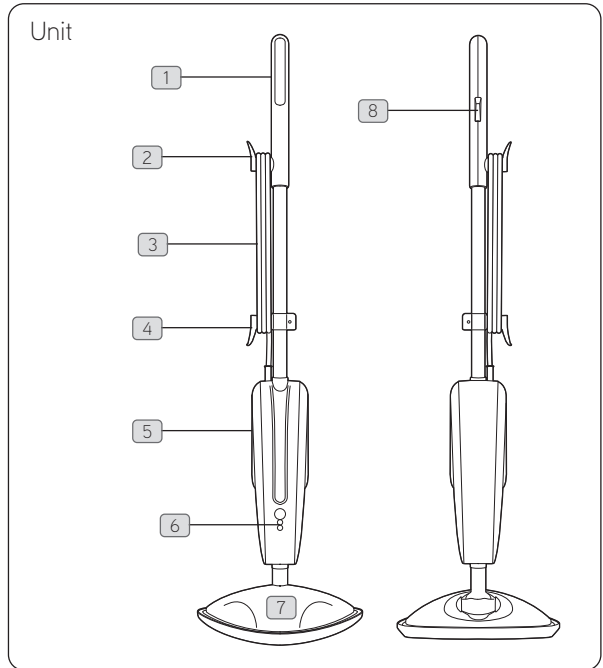

- 9 Velcro microfibre cleaning pads x 2
- 10 Carpet glider
- 11 Cooling base
- 12 Window squeegee/Upholstery tool
- 13 Hose
- 14 Concentration nozzle
- 15 Accessories storage bag
- 16 Window cloth
- 17 Grout brush
- 18 Scraper tool
- 19 Detailer tool
- 20 Small plastic brush
- 21 Large plastic brush
- 22 Metal brush
- 23 Shoulder strap
- 24 Accessories connector

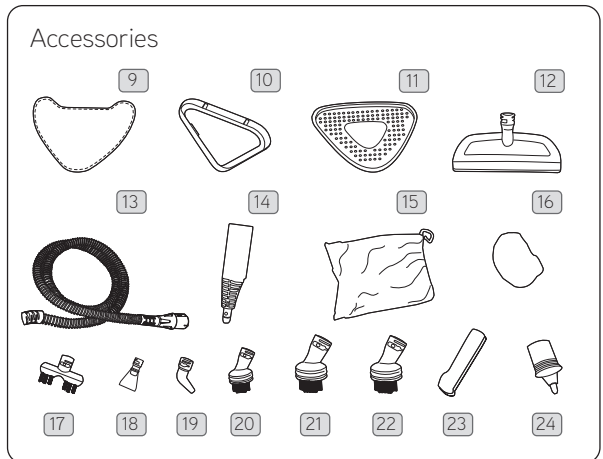

# General Safety Information

## FOR HOUSEHOLD USE ONLY.

When using the steam cleaner, basic safety precautions should always be observed, including the following:

**IMPORTANT:** Please refer to floor manufacturer's care recommendations before use and test the steam mop on a discrete area of flooring to begin with.

When using the steam mop, basic safety precautions should always be observed, including the following:

**WARNING:** The stick steam mop head gets very hot during operation.

**WARNING:**  Danger of scalding

1. Do not leave the steam mop unattended when plugged in. Unplug the product from the socket when not in use.
2. Only use the steam mop indoors. Keep the steam mop away from rain and moisture.
3. Turn off the on/off switch on the steam mop controls before disconnecting or connecting from the mains supply.
4. Always unplug the steam mop and allow it to cool before connecting or disconnecting the hose or accessories.
5. Children should be supervised to ensure that they do not play with the appliance.
6. This appliance is not intended for use by children and persons with reduced physical, sensory or mental capabilities or lack of experience and knowledge, unless they have been given supervision or instruction concerning use of the appliance by a person responsible for their safety.
7. The appliance should only be used as described in the quick start guide or in the full instruction manual.
8. Only Vax recommended attachments should be used with this appliance.
9. Do not use this steam mop if it has been dropped, damaged, left outdoors or dropped into water. Do not use this steam mop with a damaged cord or plug. If the supply cord is damaged return the steam mop to a Vax authorised Service Agent.
10. Do not pull or carry this appliance by the cord. Do not use the cord as a handle, close a door on the cord or pull the cord around sharp edges or corners. Do not run the steam mop over the cord. Keep the cord away from heated surfaces.
11. Do not unplug the product by pulling on the cord.
12. Do not handle the plug or the steam mop with wet hands.
13. Do not use without the tank cap in place. Ensure that the water tank cap has been screwed down fully before use.
14. Do not touch any hot areas on the steam mop. It is normal for the steam mop to heat up during operation.
15. Accessories will become hot during use – allow them to cool down before handling.
16. Do not use the steam mop to treat any items of clothing that are still being worn on the body.
17. The force and heat of the steam may have an adverse effect on some materials. Always check whether a surface is suitable for treatment with the steam by carrying out a test before hand on a concealed area.
18. The steam mop must be kept level during operation.
19. Never immerse the steam mop in water or in other liquids.
20. Do not operate the steam mop without water in the tank. Always top up with water in good time.
21. Always remove the mains plug from the socket and allow the steam mop to cool down completely before topping up with water.
22. Never aim the steam mop at people, animals or plants (there is a risk of scalding). Never touch the steam jet from a short distance with your hands. Do not aim the steam mop at electrical items or wires.
23. Keep hair, loose clothing, fingers and all parts of the body away from openings.
24. Never fill the water tank with anything other than water. Never put additives (such as perfume, stain remover or products containing alcohol) in the water as they may damage the steam cleaner or make it dangerous to use.
25. Only carry the steam mop by the carry handle.
26. Store the steam mop in a cool, dry area.
27. Do not use an extension cord with this product.
28. Using improper voltage may result in damage to the steam cleaner and possible injury to the user. The correct voltage is listed on the rating label.
29. Do not use your steam mop if it is damaged or faulty. Please make sure that the product is unplugged from the mains and call the Vax Careline on AU 1300 361 505 / NZ 0800 800 900.
30. Do not use the unit on leather, wax polished furniture or floors, synthetic fabrics, velvet or other delicate steam or water sensitive materials.
31. Do not use on acrylic surfaces.
32. In wet rooms, e.g. bathrooms, connect the appliance to sockets with an RCD adaptor connected in series.
33. The device should not be used to clean electrical appliances such as ovens, microwaves, televisions and electrical heating systems etc.

# General Safety Information

34. Be very careful when cleaning tiled walls with sockets.
35. Keep the unit on the floor.
36. Empty the water tank when the steam mop is not in use.
37. Do not overfill the tank. Do not exceed the maximum prescribed filling level. Please use the measuring jug and funnel included.
38. Always show these instructions to a third party if you are passing the steam mop on to them.
39. Please ensure all parts are correctly fitted before using the product.
40. Do not attempt to remove blockages with sharp objects as they may cause damage.
41. Do not use without the hard water filter in place.
42. Take extra care when cleaning on the stairs.
43. Keep cleaning area well lit.
44. Please refer to the manufacturers care recommendations before use and test the steam mop on a discrete area of flooring to begin with.



**IMPORTANT:** This steam mop may not be suitable for all floating floorboards or sealed floors – please check with your floorboard manufacturer first prior to use.

**This machine is intended for household use only, and NOT for commercial or industrial use.**

**PLEASE KEEP THESE INSTRUCTIONS FOR FURTHER USE.**



**WARNING:** Always switch off and unplug the steam mop from the electrical outlet before assembling, opening or emptying the water tank, or before connecting/disconnecting the attachments.



**IMPORTANT:** The liquid or steam must not be directed towards equipment containing electrical components, such as the interior of ovens.



**IMPORTANT:** The steam mop is equipped with a thermostat and a thermal cut-out. If for any reason the unit should overheat, the thermostat will automatically turn the unit off. Should this occur, unplug the steam mop from the electrical outlet and turn off the switch. Let the unit cool, remove and empty the water tank. To re-start the machine, plug it into an electrical outlet and switch it back on.



**IMPORTANT:** We recommend the use of a Residual Current Device with a Residual Current rating of 30mA or less.



**WARNING:** Never leave the steam mop in one spot on any surface for an extended period of time as this may damage the floor surface. Always return the mop back to the resting tray when not in use or when not continuously moving across the floor.

# Operation

## Assembling your stick steam mop

**WARNING:** To reduce the risk of personal injury, unplug the steam mop when assembling.

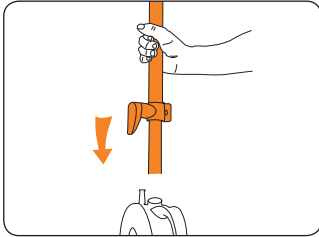

Insert handle into main body. Line up the metal locking pin with the hole and click into place.

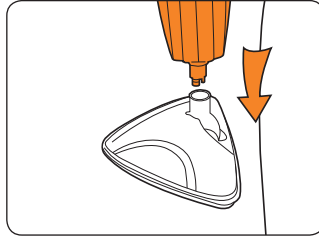

Fit the body of the unit into the steam mop floor head. Line up the white plastic locking pin with the hole and click into place.

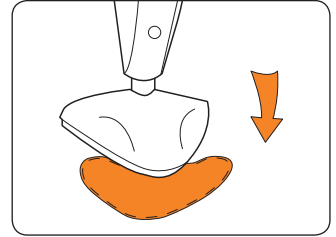

Attach the velcro microfibre cleaning pad to steam mop floor head. The **blue face** of the cleaning pad should be in contact with the floor.

## Before you begin cleaning

**WARNING:** Do not use hot or boiling water to fill clean water tank. Do not overfill the water tank.

**NOTE:** Always ensure there is water in the clean water tank.



Remove clean water tank by pressing the quick release button.

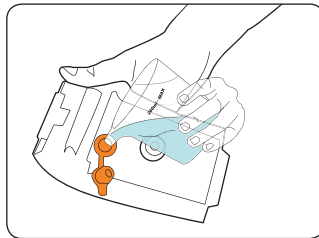

Remove the water cap and pour in 400ml of clean water. Replace the water cap.

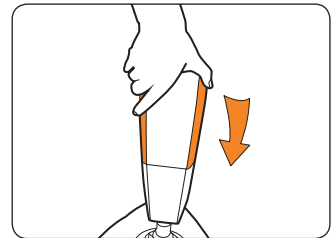

Replace the clean water tank, clicking in place making sure the hard water filter is in place.

# Operation

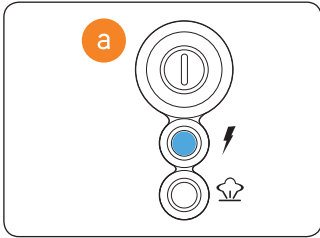

Blue LED will illuminate when the unit is switched on at the plug, the power button is pressed and the water is heating.

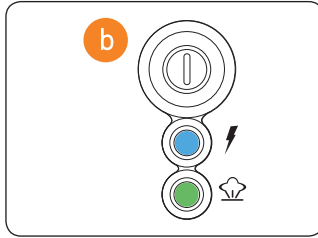

Blue LED + Green LED will illuminate within 1 minute indicating that the steam mop is ready to use. The Green LED will go off when unit water is re-heating.

## Attaching the cleaning pad

**WARNING:** To reduce the risk of personal injury, unplug the steam mop when assembling the accessories.

**IMPORTANT:** Never use the stick steam mop without the microfibre cleaning pad correctly attached to the floor head.

**IMPORTANT:** Carefully remove the cleaning pad from the floor head as the pad and floor head may be hot.

### Velcro microfibre cleaning pad

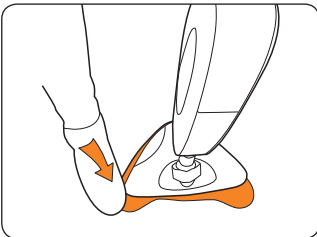

Hold corner of pad down with foot and peel unit away

# Operation

## Steam cleaning hard floors

**IMPORTANT:** Please refer to floor manufacturer's care recommendations before use and test the steam mop on a discrete area of flooring to begin with.

**WARNING:** Never leave the stick steam mop in one spot on any surface for an extended period of time with a damp or wet microfibre cleaning pad attached as this may damage the floor surface. Your stick steam mop should only be used on tiles, lino, sealed wood flooring including sealed laminate.

**WARNING:** Do not operate/use stick steam mop without water in clean water tank.

**IMPORTANT:** To reduce the risk of personal injury, unplug the steam mop when assembling the accessories.

**IMPORTANT:** When using on hard floors, always ensure the microfibre cleaning pad is properly attached to the floor head.

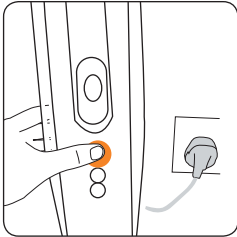

Plug into mains, press on button on the main body.

A blue light shows unit is on and heating. Wait until green light appears (within 1 minute).

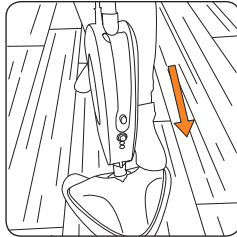

To recline the unit place foot on floor head and tilt handle.

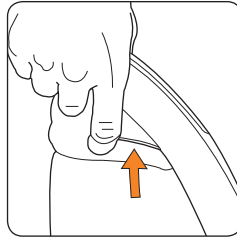

To produce steam squeeze the trigger in short bursts.

To prevent overly wetting floors, do not hold down continuously.

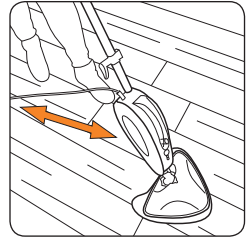

Move the steam mop slowly backwards and forwards across the floor paying particular attention to high traffic areas.

**IMPORTANT:** For 1 x 400ml water tank = 12 minutes steaming time (approx).



# Operation

## Refreshing carpets

**IMPORTANT:** When using on carpets, always ensure the microfibre cleaning pad is properly attached to the floor head.

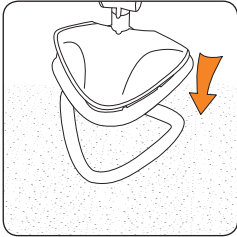

Place unit into carpet glider.

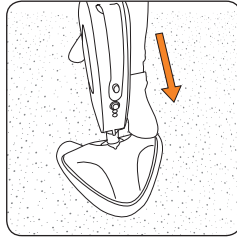

To recline the unit place foot on floor head and tilt handle.

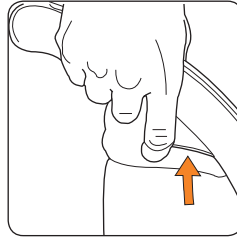

To produce steam squeeze the trigger in short bursts.

To prevent overly wetting carpet, do not hold down continuously.

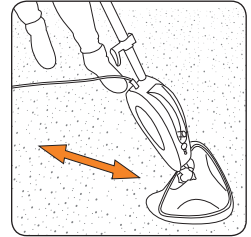

Move the steam mop slowly backwards and forwards across the floor paying particular attention to high traffic areas.

# Operation

## Using the handheld steam mop

**WARNING:** To reduce the risk of personal injury, unplug the steam mop when assembling the accessories.

**WARNING:** Always ensure there is water in the clean water tank.

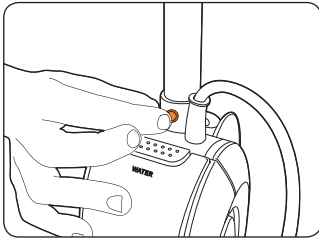

Remove handle from main body by pushing **metal locking pin** and pulling away handle.

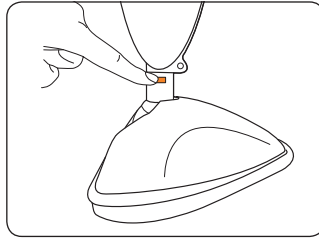

Remove steam mop floor head from main body by pushing white **plastic locking pin** and pulling away.

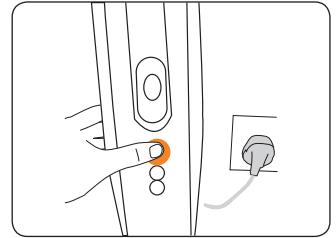

**Plug in unit, press on button.** The **BLUE LED** will illuminate when the unit is switched on at the plug, the power button is pressed and the water is heating.

The **GREEN LED** will illuminate within 1 minute indicating that the steam mop is ready to use.

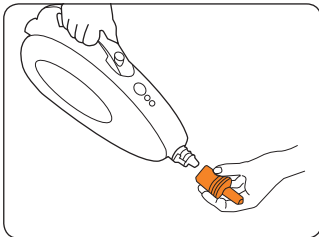

When using handheld steam mop attach the accessory connector 1 and then attach the desired accessory 2.

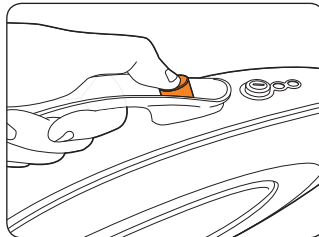

To produced steam push the button on top of the main body in short bursts.

# Maintenance (Keep your Vax as good as new)

## Empty the water tank

**IMPORTANT:** Allow the unit to fully cool down before performing any maintenance or troubleshooting checks.



Remove the clean water tank by pressing the quick release button.

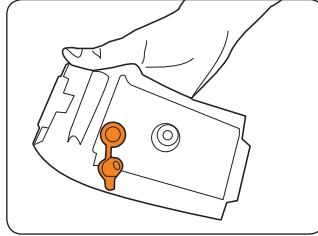

Remove the water cap.

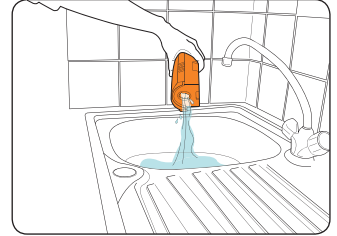

Empty any excess water over the sink, replace water cap and return to the unit.

## Removing the cleaning pad

**IMPORTANT:** Allow the unit to fully cool down before performing any maintenance or troubleshooting checks.

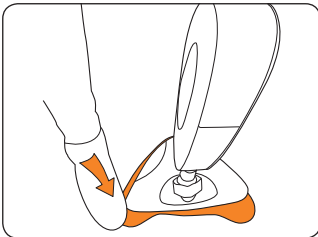

Velcro microfibre cleaning pad

Hold corner of pad down with foot and peel unit away.

## Cleaning the microfibre cleaning pad

**IMPORTANT:** Never use bleach or fabric softener when washing the microfibre cleaning pad.

- 1 Machine washable at warm temperature (max 40°C). Always use a mild detergent.
- 2 Allow to fully dry before use.

# Maintenance (Keep your Vax as good as new)

## Replacing the hard water filter

**IMPORTANT:** The condition of the filter affects the performance of your machine. Check and change filter (depending on level of use). Do not operate unit without hard water filter in place.

Your machine is fitted with a hard water filter. If you live in an area of hard water the filter will discolour/darken over time (2). Depending on water hardness and/or frequency of use the filter should be changed every 12 months, or once the filter has completely darkened.

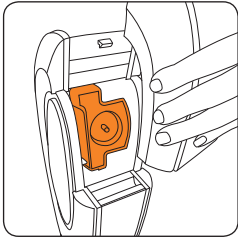

Hard water filter in unit.

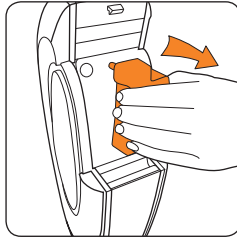

Hard water filter removed.

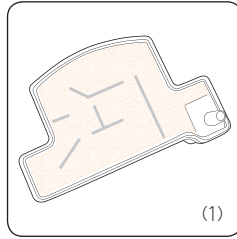

(1)

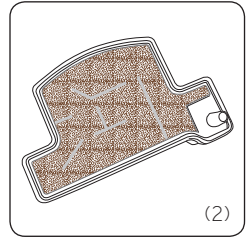

(2)

Filter needs to be replaced.

## Clearing blockages

**IMPORTANT:** Turn unit off. Allow unit to fully cool down before performing maintenance or troubleshooting checks.

There is a small opening at the bottom of the trim that goes around the outside of the back of the unit.

This opening is a steam exhaust vent should the primary path become blocked. If steam starts to escape from this vent you should:

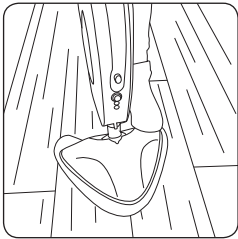

Steam exhaust vent.

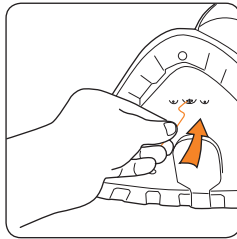

Remove microfibre pad and inspect unit base for blockages. If a blockage can be seen use a small thin object such as a paper-clip to try to free blockage.

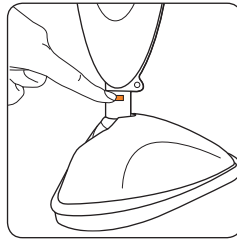

If steam path is still blocked, remove steam mop floor head from main body by pushing white plastic locking pin and pulling away.

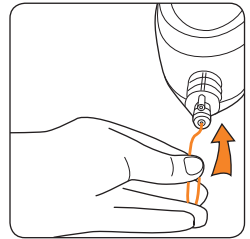

After floor head is removed, using a thin object such as a paper-clip (in the area shown), attempt to remove the blockage.

# Maintenance (Keep your Vax as good as new)



**WARNING:** To reduce the risk of personal injury, unplug the steam mop before performing maintenance/troubleshooting checks.

Problem	Cause
Is there an accessory missing?	Check the Parts Overview page in the guide to make sure the part is definitely included in your unit.
	If the part is missing we're here to help. Simply call us on: AU 1300 361 505 / NZ 0800 800 900
The steam mop cleaner has no power?	Unit may not be plugged into the electrical outlet correctly, ensure the plug is pushed in securely.
	The electrical outlet may not be working properly, check the fuse or breaker, or consult an electrician.
	The power cord may be damaged, if it is it must be replaced by the manufacturer or Vax authorised agent in order to avoid invalidating the warranty.
	When in use if the green light goes off the unit may be re-heating. The light should only take 1 minute before this comes on again.
What do I do if an accessory/the unit has become damaged or broken?	Visit <a href="http://vax.com.au">vax.com.au</a> for parts and spares.
	Please call our Careline to purchase new spares or order a replacement.
Why is the steam mop not producing steam?	There may be no water in the tank; please refer to the operation section.
	The water tank may not be fitted correctly; please refer to the operation section.
	Hard water filter may be clogged and may need to be replaced. See maintenance section.
	Steam path may be blocked, refer to cleaning blockages section.
Why won't the microfibre cleaning pad pick up dirt?	The cleaning pad may already be saturated with dirt and needs washing, please refer to the maintenance section.

## we're here to help

Instead of taking me back to the shop, simply call:

**AU: 1300 361 505**  
**NZ: 0800 800 900**

[vax.com.au](http://vax.com.au)

This does not affect your statutory rights

# Other Information

## Vax Service & Help

### Vax Careline:

Australia 1300 361 505

New Zealand 0800 800 900

Monday-Friday 8.30am to 5.00pm

If you have queries or concerns about using your Vax, call the Vax Careline. Calls are charged at the standard local rate. Please make a note of the serial number and model number of the vacuum cleaner before calling.

For the nearest Service Agent, please call the Vax Customer Careline or visit [vax.com.au](http://vax.com.au)

## Technical Specification

Voltage: 220-240V ~50/60Hz, Class I

Wattage: 1400-1600W

Water tank Capacity: 400ml

Cord length: 8m

Weight: 2.7kg

Subject to technical change without notice.



Indoor  
Use



Read  
Instructions

IPX4





**Performance is everything.™**

Distributed by Techtronic Industries Pty. Ltd.  
Level 1, 660 Doncaster Road, Doncaster, Australia 3108.  
[www.vax.com.au](http://www.vax.com.au) Service Line: AU: 1300 361 505 / NZ: 0800 800 900