

vax BLADE 2

USER GUIDE



VX80



SAFETY INFORMATION

About this user guide

Read this user guide completely before using the machine. Keep this user guide for reference. If you pass your machine on to third parties, it must be accompanied with this user guide. Failure to adhere to this user guide can lead to serious injuries or damage to the machine. We assume no liability for damage caused as a result of failure to adhere to this user guide. Important information not included in this chapter is indicated as follows:



WARNING: Warns of health hazards and identifies possible risks of injury.



CAUTION: Indicates possible dangers to the machine or other objects.

NOTE Highlights tips and information.

General usage

This stick vac is intended for household use only and NOT for commercial or industrial use.

- Only use the stick vac indoors on dry surfaces and keep the area you're cleaning well lit.
- Don't vacuum up hard or sharp objects such as glass, nails, screws, coins, etc.
- Don't vacuum up hot coals, cigarette butts, matches, or items that are burning or smoking.
- Don't use in an area that is wet or where there may be harmful fluids (chlorine, bleach and ammonia drain cleaner).

■ Don't attempt to remove blockages with sharp objects as this may cause damage to your stick vac.

■ Only Vax recommended charger, tools and accessories should be used with this stick vac and always check the floorhead and accessories are free from damage, dirt and debris before use.

■ Always turn off or unplug the stick vac from the charger before carrying out any maintenance. Please refer to the appropriate section in the user guide to review necessary precautions.

■ Always make sure the separator and filters are fitted correctly before using your stick vac.

■ Keep all openings clear and free from debris as this may affect the airflow/suction.

■ Take extra care when using the stick vac on the stairs.



WARNING: Always switch off the stick vac and unplug from the charger and mains before carrying out any maintenance or troubleshooting.



CAUTION: Don't over fill the dirt container to avoid blocking the air flow through the stick vac. For best cleaning results, empty the dirt container after every use. Filters should be tapped over a bin every 4-6 uses to remove dirt and debris and washed every 3 months. Filters should be replaced every 6-9 months depending on the level of use.

Safety

- This stick vac can be used by children aged from 8 years and above and persons with reduced physical, sensory or mental capabilities or lack of experience and knowledge if they have been given supervision or instruction concerning use of the stick vac in a safe way and understand the hazards involved. Children must not play with the stick vac. Cleaning and user maintenance must not be made by children without supervision.
- Keep fingers, hair and loose clothing away from moving parts and openings whilst using the stick vac.
- Don't use the stick vac if it has been dropped, damaged, immersed in water or left outdoors.
- Don't handle the charger plug or use the stick vac with wet hands.
- Don't use the stick vac charger if the charger cord or plug is damaged.
- Don't unplug the charger by pulling on the charger cord.

Power supply



WARNING: For the purposes of recharging the battery, only use the detachable supply unit provided with this appliance.

- Don't charge the stick vac outdoors, or leave the charger connected to the mains when not in use.
- Don't use the stick vac with the incorrect charger as this may result in damage or injury to the user. The correct charger information is listed on the ratings label.

- Always use the charger supplied with the stick vac. If charging the stick vac through an extension cord, use only SAA approved 10amp extension cords. Care should be taken to arrange the extension cord as it can be a trip hazard.

Brushbar



WARNING: The brushbar in the powered head constantly rotates when switched on. Never use the powered head on one spot for an extended period of time as the brushbar may damage the floor surface. Always turn the powered head brushbar off when cleaning hard floors. To prevent any damage being sustained, test on an inconspicuous area of the flooring first.



CAUTION: If the brushbar in the powered head has been obstructed, the brushbar motor protection sensor may have been activated. The brushbar will stop and the light on the powered head will illuminate red. To reset switch the brushbar and stick vac off, remove the powered head from the reach wand/handheld and clear any obstruction. Wait 1 minute before refitting the powered head tool, switch the stick vac on and press the brushbar ON/OFF button.

Storage

■ Store your stick vac in a cool, dry area. If filters have been cleaned as per user guide instructions ensure they are thoroughly dry before storing away. This stick vac does not stay upright without constant support. Between uses, lie flat on the floor in a suitable location so that it does not become a trip hazard or can be stepped on.

Battery and Disposal



CAUTION: The battery used in this device may present a risk of fire or chemical burn if mistreated. Do not disassemble or heat above manufacturer's maximum temperature limit (60°C/140°F) or incinerate. Use of another battery may present a risk of fire or explosion.

■ The battery is to be disposed of safely at your local battery recycling centre.

■ Do not attempt to disassemble the battery, remove any component projecting from the battery terminals and do not dispose of in a fire. The battery and charger have no user serviceable parts. Fire or injury may result.

Battery Safety Precautions:

■ Do not place vacuum or batteries near fire or heat. This will reduce the risk of explosion and possible injury.

■ Do not crush, drop or damage

battery pack. Do not use a battery pack or charger

that has been dropped or received a sharp blow. A damaged battery is subject to explosion. Properly dispose of a dropped or damaged battery immediately.

■ Batteries can explode in the presence of a source of ignition, such as a pilot light. To reduce the risk of serious personal injury, never use any cordless product in the presence of open flame. An exploded battery can propel debris and chemicals. If exposed, flush with water immediately.

■ Do not charge vacuum in a damp or wet location. Following this rule will reduce the risk of electric shock.

■ For best results, charge the battery tool in a location where the temperature is more than 10°C but less than 37°C. To reduce the risk of serious personal injury,

do not store outside or in vehicles.

■ Under extreme usage or temperature conditions, battery leakage may occur. If liquid comes in contact with the skin, wash immediately with soap and water, then neutralize with lemon juice or vinegar. If liquid gets into the eyes, flush them with clean water for at least 10 minutes, then seek immediate medical attention. Following this rule will reduce the risk of serious personal injury.

■ Store the battery pack where the temperature is below 27°C.

■ The battery must be removed from the appliance before it is scrapped.

■ The appliance must be disconnected from the supply mains when ever removing the battery.

■ The battery is to be disposed of safely.



WARNING: WARNING: For the purpose of recharging the battery, only use detachable supply unit type ZD24W340060 provided with this appliance.

Charger Safety Precautions:

■ The charger must not be damp, and should never be used in a damp environment.

■ Do not use the charger if it has suffered any heavy shock or jolting, or is damaged in any other way.

■ Do not conduct charging in a position which may become exposed to sunlight or other heat source. Recommended temperature range at charging vicinity is 10° to 25° C.

■ Do not conduct charging operations in the vicinity of flammable materials. Example: Cloth, packaging materials, paint, spray paint or aerosols, lubricant, thinners, petrol containers, gas containers or gas appliances.

■ Do not cover any ventilating slots and provide adequate ventilation during operation.

■ Never modify, disassemble or attempt to repair the product yourself.

■ Do not allow the charger or

batteries to become contaminated with any material which could be conductive.

■ Remove the plug of the product from the power socket when it is not in use or when cleaning it.

■ Protect battery contacts to avoid a short circuit caused by metallic objects which could cause a fire or explosion!

■ Do not charge batteries which show signs they have leaked electrolyte. Dispose of them properly.

■ Never charge a damaged battery.

PLEASE KEEP INSTRUCTIONS FOR FURTHER USE

WELCOME TO VAX

Thank you for buying the Vax BLADE 2, we hope you enjoy using your new product.

This user guide will help you get the most out of your machine and gives advice on maintenance and cleaning.

GET IN TOUCH

Need help with your machine?

For troubleshooting tips and machine help see page 15 or visit vax.com.au / vax.co.nz

Alternatively, our Customer Care Team is here to help and provide support with assembly, operational or performance problems, and buying and fitting new accessories.

Call us on:

Australia: 1300 VAX AUS (1300 829 287)*

New Zealand: 0800 VAX NZL (0800 829 695)*

*Monday – Friday: 8:30am -5:00pm

Calls are charged at the standard local rate. Please make note of the serial number and model number of the product before calling.

REGISTER

Register online at vax.com.au / vax.co.nz

YOUR MACHINE

Make a note of your machine details:

Model: _____

Serial Number: _____



* 1 year guarantee on battery

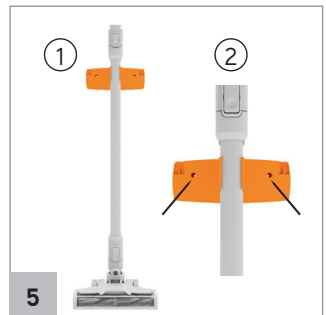
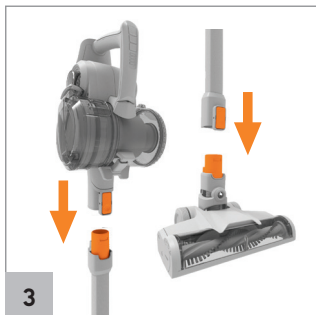
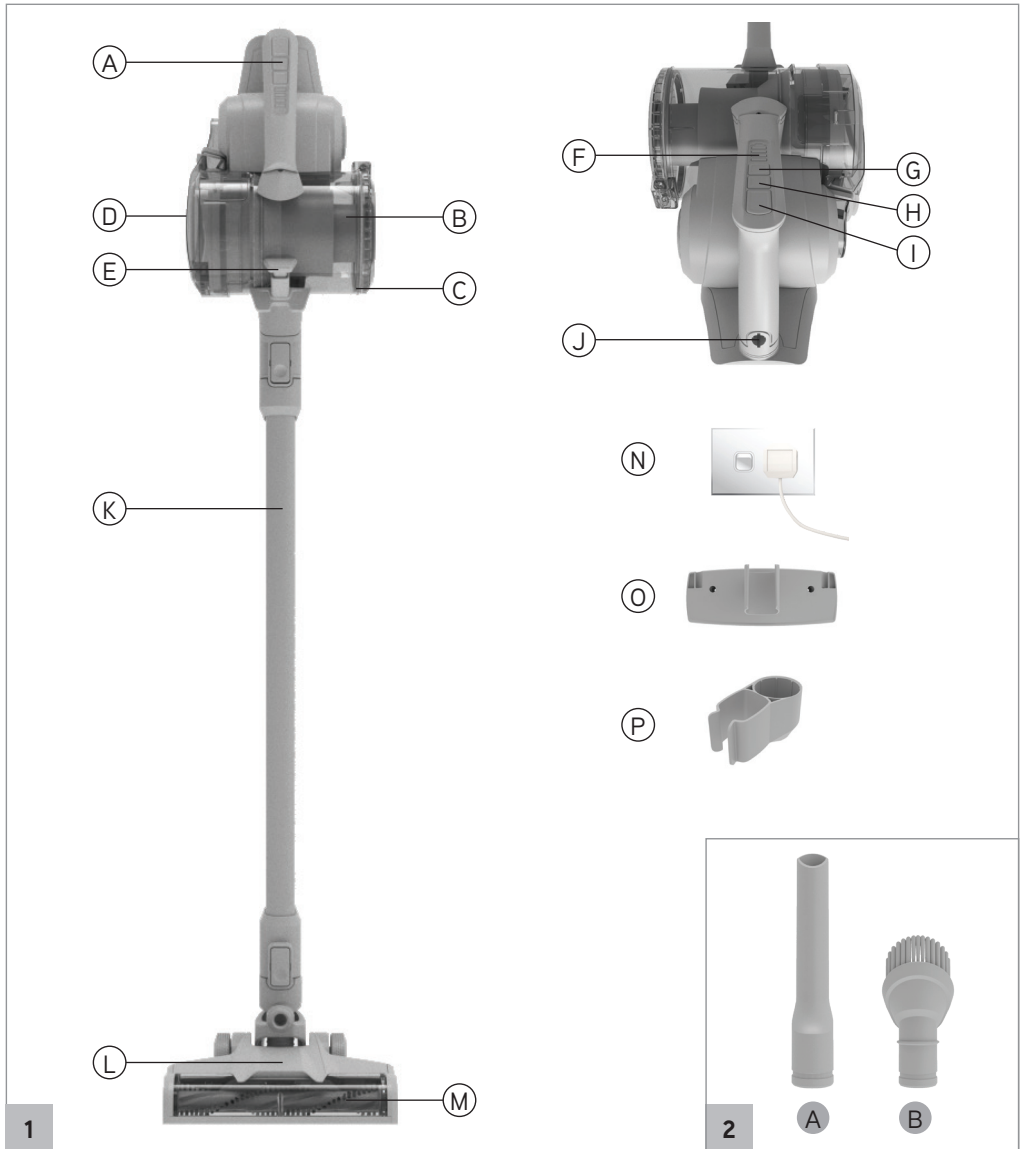

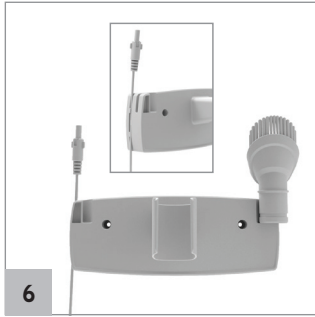

6

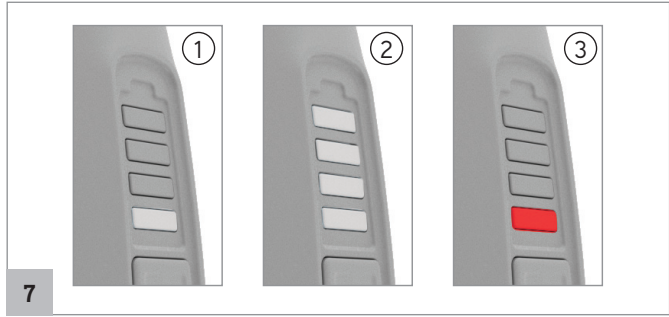

7

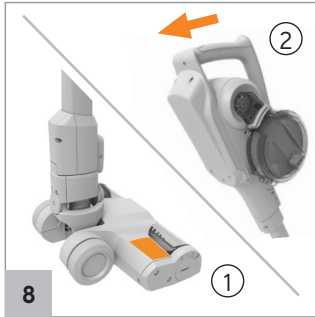

8

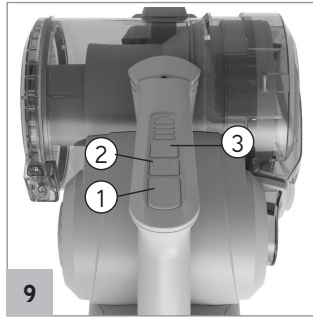

9

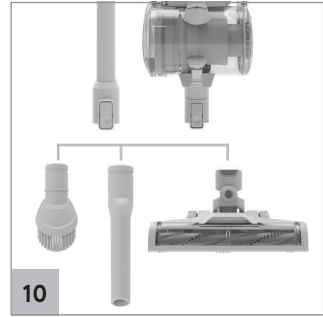

10

Technical Specification

Name	Blade 2
Model number	VX80
Battery voltage	29.2V
Run time	Up to 45 mins*
Charge time	3 hours
Weight	3.4kg
Dust bin capacity	0.6l



Charger Specification

Model number	ZD24W340060
Input voltage	100-240V ~ 50/60Hz
	0.8A Max
Output voltage	34.0V --- 600mA

Battery Specification

Type	Lithium-Ion rechargeable battery
Rating	2.0 Ah 58.4Wh / 29.2V

Use with Etek model ZD24W340060 charger only

Accessories & Consumables

Pre-motor filter **Model No. VX82F**

To purchase consumables and accessories, please visit vax.com.au / vax.co.nz

Subject to technical change without notice.

*Runtime based on machine hard floor usage with Brushbar and boost off.

It is recommended that the Powered Brushbar is turned off for use on Hard Floors.

Images are illustrative only.

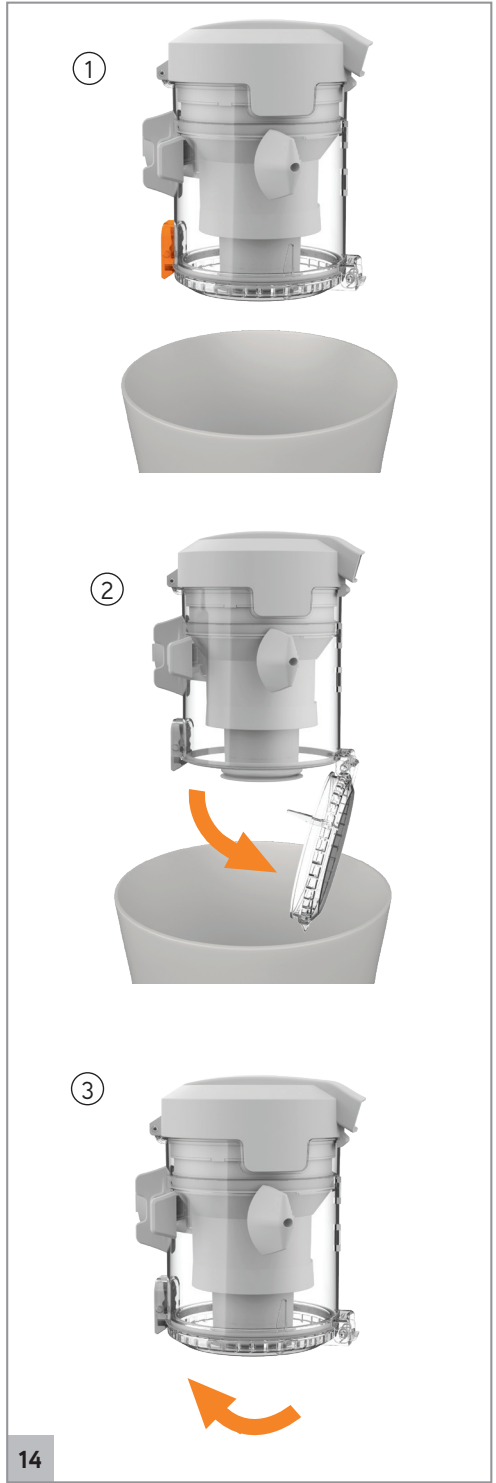
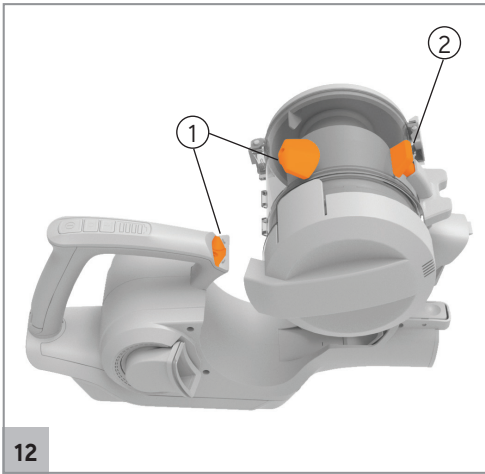
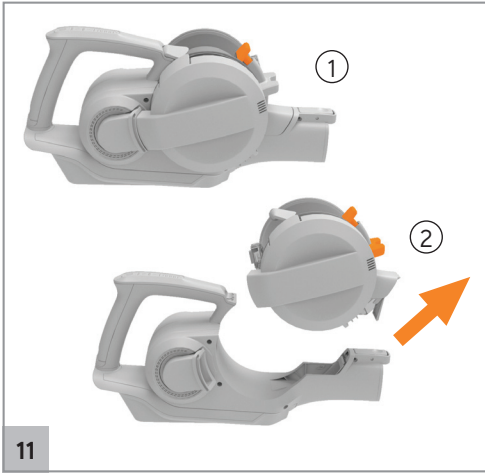



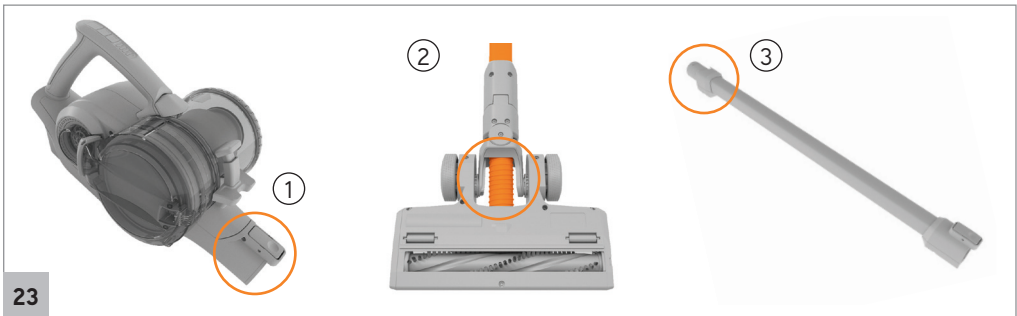
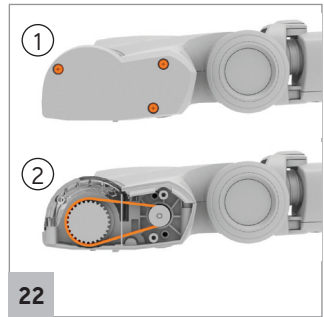
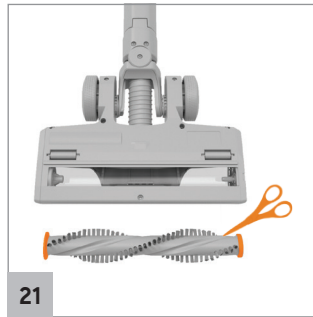
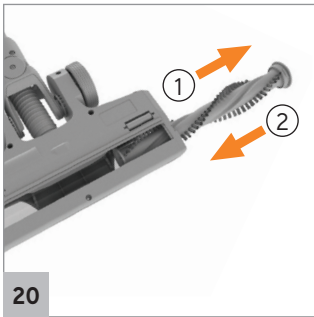
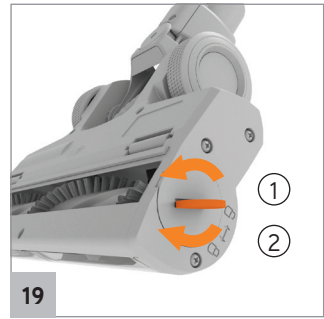
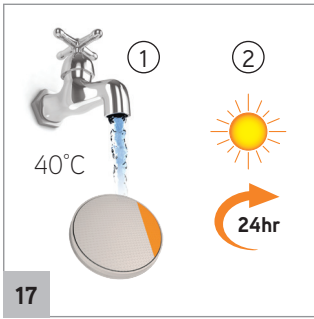



Accessories



1



2



3

1	Crevice Tool	
2	Dusting Brush	
3	Filter	VX82F

24

GETTING TO KNOW YOUR MACHINE

Fig. 1

- A. Carry handle
- B. Dirt container
- C. Dirt release button
- D. Filter cover and filter
- E. Dirt container release latch
- F. Battery level indicator light
- G. Boost button
- H. Brushbar ON/OFF button
- I. ON/OFF button
- J. Charging port
- K. Reach wand
- L. Powered head
- M. Brushbar
- N. Charger
- O. Wall mount, 2 screws and wall plugs
- P. Crevice tool storage caddy

Contents Fig. 2

- A. Crevice tool
- B. Dusting brush

Unpacking and assembly

1. Unpack the contents and check they are complete. (Fig. 1 and 2).
2. Attach the reach wand and powered head to the handheld. They will click when locked into place (Fig. 3).
3. Push the crevice tool storage caddy onto the reach wand and slot the tool into place (Fig. 4).

Attaching the wall mount

1. Without the handheld attached to the reach wand and powered head, push the wall bracket onto the top and back of the reach wand. (Fig. 5/1).
2. Choose a location for the stick vac to be stored, preferably near to a mains supply although not directly above or below a mains socket. Stand the stick vac powered head and wand against the wall, ensuring the powered head is flat on the floor.

3. Holding the wall bracket securely against the wall, use a pencil to make a small mark for each screw. (Fig. 5/2) Use the screws and wall plugs to secure the wall bracket to the wall.

4. The charger cord and dusting brush can be fitted onto the wall bracket (Fig. 6).

5. Fully assemble the stick vac and firmly press the stick vac into the wall bracket to secure. Always ensure the stick vac is securely locked into place.

Charging the stick vac

NOTE The initial charge is 4 hours and charging will be required before first use. Failure to fully charge the battery before first use may result in poor battery performance. The life expectancy of the battery will vary depending on the usage of the stick vac.

1. To charge the stick vac, securely attach the stick vac into the wall bracket. You can also charge as a handheld; detach the stick vac from the reach wand and tools, and place on a flat, stable surface.
2. Insert the charger lead into the charging port (Fig. 1/J) located on the carry handle of the handheld and plug the charger plug into the mains.
3. The battery indicator level lights will illuminate in turn as the battery charges, until all four lights are illuminated (Fig. 7/1 and 7/2) Once fully charged, the lights will go out. If charging for the first time the initial charge time is 4 hours.
4. When the stick vac is in use the battery level indicator lights will illuminate indicating how much charge is remaining.

When less than 20% charge is remaining the bottom light will flash red indicating the battery is running low and charging is required (Fig. **7/3**).

Using the stick vac

 **WARNING:** The brushbar in the powered head constantly rotates when switched on. Never use the powered head on one spot for an extended period of time as the brushbar may damage the floor surface. Always turn the powered head brushbar off when cleaning hard floors. To prevent any damage being sustained, test on an inconspicuous area of the flooring first.

 **CAUTION:** If the brushbar in the powered head has been obstructed, the brushbar motor protection sensor may have been activated. The brushbar will stop and the light on the powered head will illuminate red (Fig. **18**). To reset switch the brushbar and stick vac off, remove the powered head from the reach wand/handheld and clear any obstruction. Wait 1 minute before refitting the powered head tool, switch the stick vac on and press the brushbar ON/OFF button.

1. Place your foot on the powered head (Fig. **8/1**) and pull the handle backwards to recline (Fig. **8/2**).

2. To switch the stick vac on, press the ON/OFF button located on the handle (Fig. **9/1**). The On/Off button and battery level indicator lights on the handle will illuminate (Fig. **7/2**).

3. To increase suction for particularly dirty areas that require additional cleaning boost mode can be activated (Fig. **9/3**). When the stick vac is switched on, the boost on/off button will also illuminate, confirming that the boost mode is 'On'. Pressing the boost button will deactivate/activate the boost mode.

4. To switch the brushbar on, press the brushbar ON/OFF button (Fig. **9/2**). The light on the powered head and the brushbar ON/OFF light will illuminate when the brushbar is on and the brushbar will constantly spin. Press the brushbar ON/OFF button again to turn the brushbar off.

NOTE: The powered head brushbar should be ON for carpets and OFF for hard floors. Constant use of the boost mode and brushbar will reduce the battery run time.

5. All of the accessories, including the powered head can be attached directly onto the handheld (Fig. **10**) or the reach wand. The crevice tool and dusting brush can be used for hard to reach places and at different heights for above floor cleaning.

MAINTAINING THE STICK VAC

 **WARNING:** Always switch off the stick vac and unplug from the charger and mains before carrying out any maintenance or troubleshooting.

Removing and refitting the dirt container

1. Push down the latch on the dirt container (Fig. **11/1**) to release, tilt and lift to remove the dirt container from the stick vac. (Fig. **11/2**).

NOTE: Before refitting, if the lid of the container with separator has been removed for cleaning make sure the separator has been locked into place (Fig. 13).

2. To refit, line up the dirt container connection with the stick vac handle (Fig. 12/1). Press the dirt container release latch (Fig. 12/2) and push the dirt container onto the stick vac. Release the dirt container latch to lock the dirt into place.
3. When correctly fitted all 3 connection points will be aligned and will sit flush (Fig. 13).

Emptying the dirt container

1. Push down the latch on the dirt container (Fig. 11/1) to release, tilt and lift to remove the dirt container from the stick vac. (Fig. 11/2).
2. Hold the dirt container over a bin and press the dirt release button to allow dirt and debris to fall out. (Fig. 14/1 & 2).
3. To close, push the dirt release door until it locks into place (Fig. 14/3).

 **CAUTION:** Don't over fill the dirt container to avoid blocking the air flow through the stick vac. For best cleaning results, empty the dirt container after every use. Filters should be tapped over a bin every 4-6 uses to remove dirt and debris and washed every 3 months. Filters should be replaced every 6-9 months depending on the level of use.

Cleaning the filter and separator

1. Empty the dirt container (Fig. 14).

2. Push the tab on the lid of the dirt container to access the filter (Fig. 15/1 & 2). Lift the filter cover and separator from the dirt container (Fig. 15/3).

3. Tap the separator over a bin to remove dirt and debris and wipe over the metal shroud with a dry cloth (Fig. 16/1).

4. Pull the tab on the filter to remove from the separator (Fig. 16/2). Tap the filter against the bin to remove any dirt and debris (Fig. 16/3).

5. Wash the filter under running water (40°C max) (Fig. 17). Leave for at least 24hrs or until fully dry before replacing.

Cleaning and replacing the powered head brushbar

1. Using a coin, push and turn the brushbar lock anticlockwise to release the brushbar (Fig. 19/1).

2. Pull the brushbar out from the brushbar housing (Fig. 20/1).

3. To remove any threads or hair, slide the blade of a pair of scissors into the groove on the brushbar and cut along the groove. Clear any dirt/debris from the end caps and inside the housing of the powered head (Fig. 21).

4. Refit the brushbar (Fig. 20/2) and turn the brushbar lock clockwise to lock (Fig. 19/2).

Removing and replacing the powered head belt

1. Using a cross head screwdriver, unscrew the 3 screws and remove the cover (Fig. 22/1)

2. If the belt is broken, remove the old belt and clean any debris from the cogs. To replace the belt firstly hook the belt over the small cog. Slide the belt over the

top of the large cog and rotate the belt and cog anticlockwise. During rotation the belt will slide onto the cog (Fig. 22/2)

3. Refit the belt cover and tighten the screws to secure.

Checking for blockages

1. Press the handheld release button and remove the reach wand. Check and clear any dirt and debris from the handheld connection point and the bin inlet. (Fig. 23/1).

2. Check the powered head for any blockages and use a blunt object to remove the blockage. (Fig. 23/2).

3. To test for a blockage in the reach wand, drop a small ball of paper into the wand. The paper will drop through if the wand is clear. Use a broom handle or similar blunt object to remove any blockage (Fig. 23/3).

TROUBLESHOOTING

There is an accessory missing

Check the contents (Fig. 2).

Why does the stick vac have no power?

■ The stick vac may need recharging.

Go to **Charging the stick vac.**

■ The motor thermostat may have tripped. Empty the dirt container and check for blockages. Clean the filters and allow the stick vac to cool for approximately 1 hour. If you have washed the filters, wait 24 hours to fully dry before placing back on the stick vac.

Why won't the stick vac pick up?

■ The dirt container may be blocked. Check the dirt container and hand held inlet for blockages.

Go to **Emptying the dirt container.**

■ The filters may be clogged. Go to **Cleaning the filter and separator.**

■ There maybe a blockage.

Go to **Checking for blockages.**

■ The brushbar on the powered head has not been activated. Go to **Using the stick vac.**

■ The powered head may be blocked. Go to **Cleaning and replacing the powered head brushbar.**

■ The stick vac, powered head and reach wand may not be correctly fitted. Go to **Unpacking and assembly.**

Why is there a red light on the unit?

■ Battery charge is running low (<20%).

Go to **Charging the stick vac.**

Why is there a red light on the powered head?

■ The powered head brushbar has been obstructed. Go to **Cleaning and replacing the powered head brushbar.**

Why won't the powered head turn?

■ The brushbar on the powered head has not been activated. Go to **Using the stick vac.**

■ The tool/brushbar may be obstructed. Go to **Cleaning and replacing the powered head brushbar.**

■ The stick vac, powered head and reach wand may not be correctly fitted. Go to **Unpacking and assembly.**

■ The belt on the tool may be broken. Go to **Removing and replacing the powered head belt.**

vax

Distributed by

Techtronic Industries Australia Pty Ltd

31 Gilby Road, Mount Waverley, VIC 3149, Melbourne, Australia
Careline AU: 1300 VAX AUS (1300 829 287) www.vax.com.au

Techtronic Industries N.Z. Limited

2 Landing Drive, Mangere, Auckland, 2022, New Zealand
Careline NZ: 0800 VAX NZL (0800 829 695) www.vax.co.nz